



## PRESENCE MOBILE MOTORIZED XL

**SKU:** C5-31U007-2-C-0

The XL version of our unique design product. Attractive and elegant from all sides, the Presence Mobile Motorized XL looks great placed in the centre of the room. Perfect for large, heavy (up to 150 kg!) and touch sensitive displays, due to the very stable and patented design.

The motorised height adjustment is soft and quiet, readily available from a button at the side of the unit. Cables and peripherals are completely hidden inside.

Motorized height adjustment works for most markets (both 110 and 230V) and allows you to work ergonomically.

The display can be locked with the accompanying locking screw for personal safety, or with a padlock (not included), providing increased protection from theft.

The pre-factory assembly means that installation is easy and quick, while the hidden cable chain inside the product ensures that the cables run freely.

The design of the SMS Presence is, furthermore, protected.

Maximum display weight: 150 kg.

Finish: Aluminium/Anthracite grey.



---

**Max weight** 150

**Warranty** 2

**Max Screen size** max 84" (85-98" max 100kg)

**Motorized** 1

**Motorized spec** 100 VAC – 240VAC, 50/60 Hz

**VESA Horizontal** 200 - 1200

**VESA Vertical** 100 - 600

**Height adjustable spec** Stroke length 500mm

**Placement** Mobile

**Certificates** CE

GALLERY IMAGES

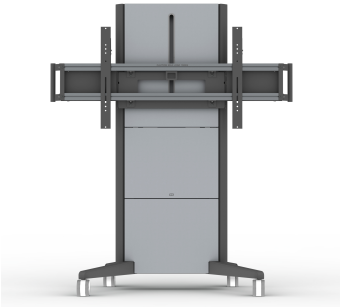

*We reserve the right to introduce changes in the product specifications after the printing and publication of this document.*

*Visit [www.smartmediasolutions.com](http://www.smartmediasolutions.com) for the most recent information.*

SMS Smart Media Solutions AB

Högbergsgatan 26B, 116 20 STOCKHOLM